



VENTILATION SYSTEM INSTALLATION

RESIDENTIAL SERIES ● recuperators



Use the QR code or visit the website: prana.help/b22 to view information about the device, user manual and other useful information.

- Do not try to install it yourself without proper qualifications.
- For safe and correct installation of the device, first read carefully all the information concerning safety measures and rules.
- Improper installation voids warranty service.
- PRANA is not responsible for the installation performed by an unqualified specialist (group) and all subsequent consequences.

MODEL RANGE: PRANA 2022 ®

CONTENT

WARNINGS AND SAFETY MEASURES	4
MAIN INSTALLATION STEPS	6
MAIN PRINCIPLES	7
ELECTRICITY CONNECTION	14
FIRST START	15
POSSIBLE INSTALLATION ERRORS	16

- This device may be used by children from the age of 8 years, as well as by physically or sensory disabled or mentally challenged persons or people with lack of experience and knowledge, provided that they are supervised or instructed about the safe operation of the device and understand the dangers involved. Do not allow children to play with the device.

Cleaning and maintenance should not be performed by unsupervised children.

- A user without proper qualifications must not install, move, disassemble, modify or repair the recuperator themselves.

- During the operation of the device, the fan rotates inside it. Avoid getting foreign objects inside the device during operation.

This may result in injury.

- Make sure that the outdoor air intake is located so that smoke or other harmful gases do not enter it. If the intake air is polluted, the quantitative and qualitative indicator of oxygen in the room may decrease.

- Do not place heating equipment in the way of the air intake by appliance. Products of incomplete combustion can lead to accident.

- Mounting by unqualified person may result in reduced system performance, product damage or accidents.

- In case of plugging in with the power plug, do not pull on the cord while trying to unplug it.

The power plug must be firmly plugged into the outlet. Otherwise, it may result in electric shock.

- The recuperator is connected by means of isolated strong conductors (cable and wires) with a cross section of 0.5-0.75 mm².

Electrical installation must be performed by a qualified specialist in accordance with the «Electrical Installations Code».

- Do not use the device at a temperature of +50 °C and above, near open flames, in places exposed to smoke or where it may come into contact with organic solvents. This may cause a fire.

- Do not block the supply and exhaust channels, as this will reduce the quality indicators of the recuperator and may lead to system failure.

- The recuperator is mounted in a hole of appropriate diameter (depending on the model) with a slope of 2-3° towards the street. Also, the housing (excluding the rear air intake) should protrude beyond the wall towards the street by 1-2 cm.

Non-compliance may lead to condensed moisture in the room and cause equipment failure.

- In the event of damage of the recuperator, immediately de-energize the system with an automatic circuit breaker or unplug it.

Continued use of the recuperator may result in smoke, fire, electric shock or injury.

- The system must be connected to the power supply network via a circuit breaker or a power plug

- The appliance must be de-energized before carrying out any operations of maintenance service (unplug the appliance or turn off the main power switch and wait for the fans to come to a complete stop).

- If the outdoor air temperature is +20°C and above, do not switch on the functions of «Mini heating», «Winter mode», «Defrost».

- In order to avoid icing and ensure the correct operation of the system at subzero temperatures outside, the use of functions «Winter mode» and «Mini-heating» is mandatory.

- Before switching on it is necessary to open an air intake, accordingly, after use to close it (if there is no need to use a passive mode of operation).

When using the system with the air intake closed, it can damage the recuperator.

- It is necessary to make sure that the conditions, mechanical and electric installation norms applied in the country where the installation is performed are observed.

- PRANA is not responsible for the installation performed by an unqualified specialist (group) and all subsequent consequences.

Improper installation voids warranty service.

- Do not twist, damage, or modify the power supply cord. Do not expose it to heat or place heavy objects on it.

These actions may result in fire or electric shock. If the power cord is damaged, in order to avoid danger it must be replaced in a service center or by a qualified person.

- The system is mounted on a sealant or foam (which does not create a deformation effect on the system housing).

- To prevent back draft in rooms where fireplaces, gasfired water heaters and other equipment that creates or uses different mixtures of gases operate, the use of «Separate control» mode is not allowed.

MAIN INSTALLATION STEPS

The list of actions that must be performed for the correct installation of the PRANA ventilation system. All the necessary items are described in this manual.

- Defining the mounting area
- Fixing the drill at an angle (ensure the inclination of the hole outdoors)
- Diamond drilling
- Power supply to the mounting area
- Control of the condensate heating position
- Control of condensate drain hole positions
- Check the density of internal channels
- Installation of the recuperator and its sealing
- Electrical installation
- First start of the system

These items are partly or fully described in this manual. For additional comfort we recommend using a nozzle with an industrial vacuum cleaner.

During drilling use water or other type of cooling only when necessary, notifying in advance the consequences for the client (for the completed repair).



DETERMINATION OF THE MOUNTING AREA

The system is mounted in the upper part of the outer wall, in a hole of appropriate diameter (depending on the model) on the seal or foam (which does not create a deformation effect on the system housing).

The minimum distance to the flat surface (walls, ceilings, etc.) is 100 mm for the PRANA 160 series, and 150 mm for the PRANA 210 series.

In order for the location of the recuperator to create a convection zone, it is necessary to provide free space in front of the system (do not cover with curtains, interior items, etc.).

If there are devices in the room that consume in door air in order to ensure the combustion process (gas boiler, fireplace, etc.), it is recommended to mount the recuperator at the maximum possible distance from these devices.

The working module is made of a length corresponding to the wall thickness, where the installation is planned in accordance with the minimum and maximum available length of the working module of the recuperator.

Detailed information on the minimum and maximum possible system sizes can be found in the quick user's guide that comes in set.

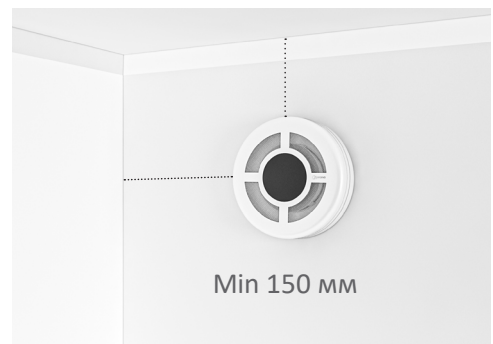

Air conditioner and recuperator work in the same room and complement each other: the first creates coolness, the second keeps it and supplies fresh air and vice versa if we talk about the cold season.

If the recuperator is installed in the same room with the air conditioner, the recommended distance between these two devices should be provided so that both work effectively.



Forbidden!

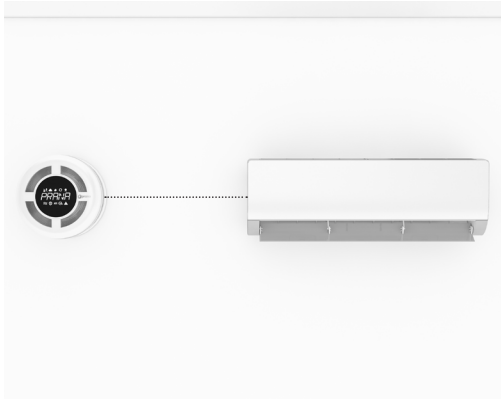

Minimum 300 mm



Minimum 300 mm

In order for the location of the recuperator to provide the correct convection zone, it is necessary:

- Do not block the air exchange with curtains;
- Interior items;
- In other ways.

Obstacles in the way of air inflow actually stop it, the pressure and flow rate approach zero level.

In this case, the exhaust channel of the recuperator removes freshly supplied air from the room, leaving the ventilation effect only within the obstacle.

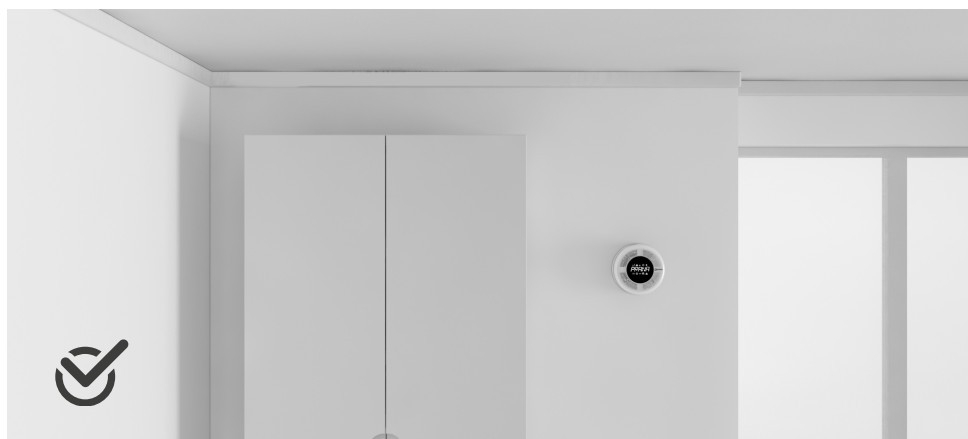

It is not recommended to install the system in the so-called «dirty premises» (rest rooms, shower rooms, bathrooms, etc.).

In these premises, according to current regulations, it is necessary to arrange only an exhaust ventilation system.

It is not recommended to mount the system at a distance of less than 5 (five) meters from the location of the cooking tops.

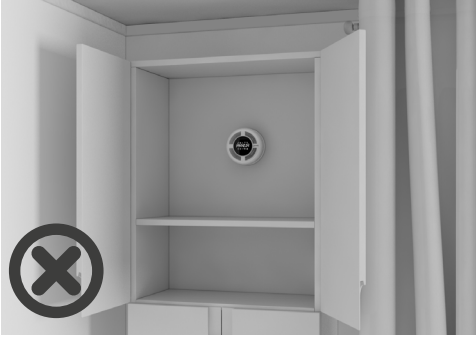

While installing in the recreation premises and sleeping areas, the systems should be installed on the opposite side from the zone of the permanent human presence.

In the cold season, the temperature of the supply air flow will be lower than the indoor temperature.

As a result, supply air flow will be falling into the zones of the permanent human presence that can cause a discomfort and feel like a draft.

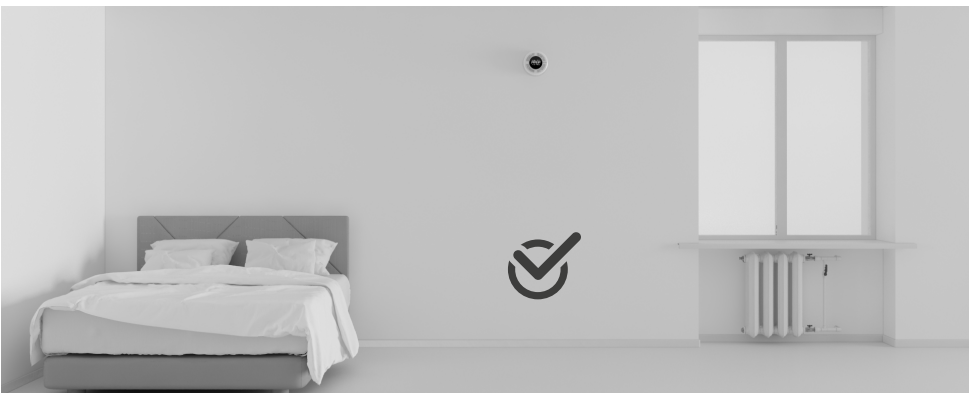

Also, a mechanical ventilation device is a new source of noise that can interfere with rest and sleep.

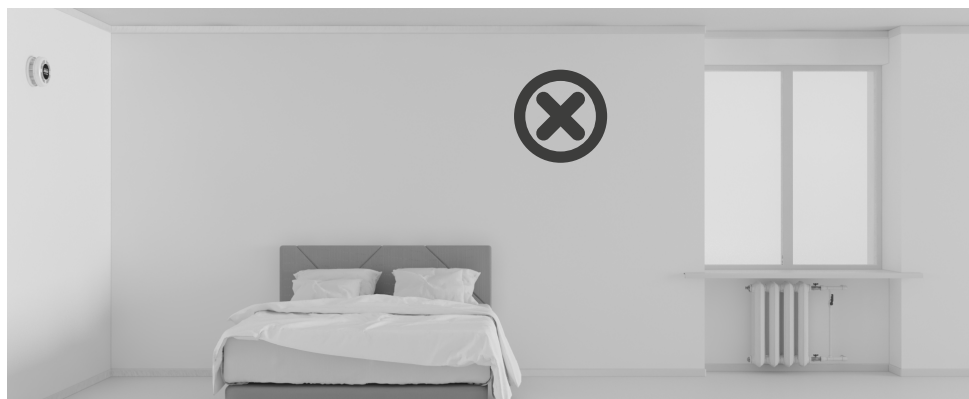

Recuperator hole diameter, depending on model:

- PRANA 160 series - hole not less than 162 mm;
- PRANA 210 series - hole not less than 220 mm.

To ensure the normal operation of the system, it is necessary that its housing, which faces the street, protrudes beyond the wall by 1-2 cm before the start of the air intake.

If the system housing protrudes more than 5 cm beyond the wall before the air intake, it is recommended to insulate the housing without covering the air intake grilles and the condensate drain hole.

The through-hole should be made with a slope of 2-3° towards the street.

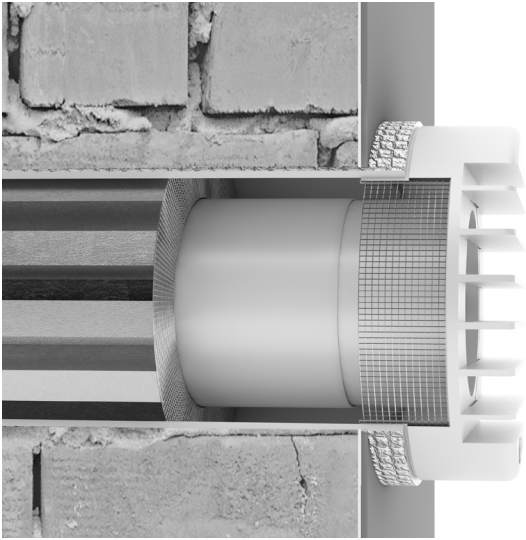

The outer cover cannot be turned over.

Do not cover the air intake grilles and the condensate drain hole. When planning the facade insulation of external walls, make sure to consider their thickness when determining the total length of the working module.

Make sure that the outer cover is located in such a way that eliminates the possibility of contaminants to enter the system (emissions of gas boilers, other exhaust devices, odors, dirt, smoke, precipitation, etc.).



The condensate drain hole must be placed vertically downwards.

The condensate heater is located at the bottom; its end is located in the hole of the condensate drain and should be at the lowest radial point.

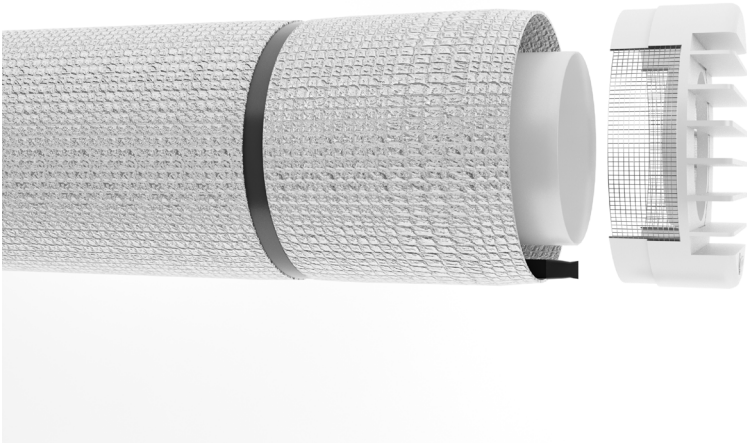
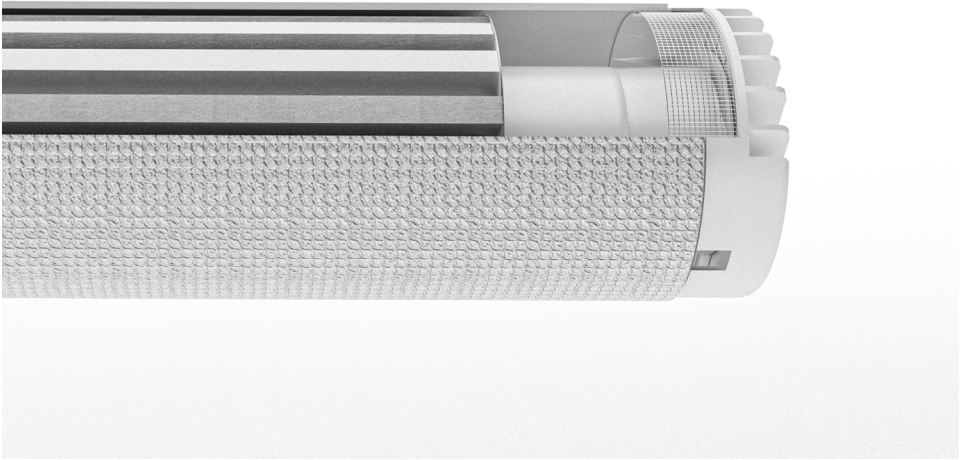

ELECTRICITY CONNECTION

The ventilation system is connected to the power supply network with a voltage of $\sim 230\text{V}$ and a frequency of 50 Hz .

The connection of the ventilation system to the power supply network is provided by an electric cable (by default 30 cm), which is removed from the operating module.

All electrical cables involved in the installation must have a cross section of $0.5\text{-}0.75\text{mm}^2$.

If the power supply network is not connected to the mounting hole, the electric cable from the recuperator should be connected to the power supply network in the junction box according to the scheme: connect terminals 1 and 2 in parallel or install an electrical connector on the cable that meets the parameters for quick connection and disconnection of electrical appliances.

The system is controlled by the means of the remote control, mobile application; details can be viewed in a quick user's guide.

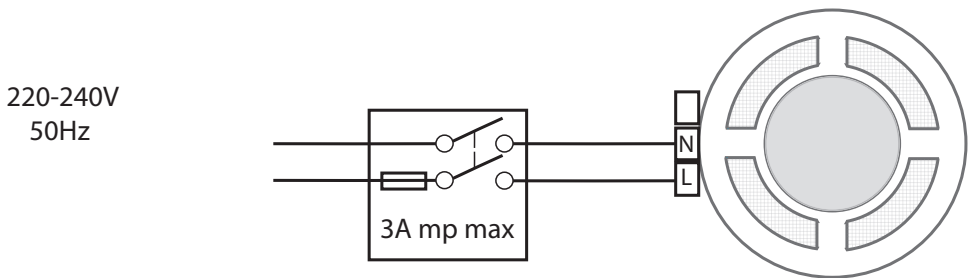

Class II or double insulated electrical appliance



Before starting, check:

- whether the connection to the power supply network is correct;
- whether the air intake is open.

Before switching on the system, open the air intake, accordingly, close it after use (if you do not want to use other modes of operation that involve closing the front cover of the recuperator).

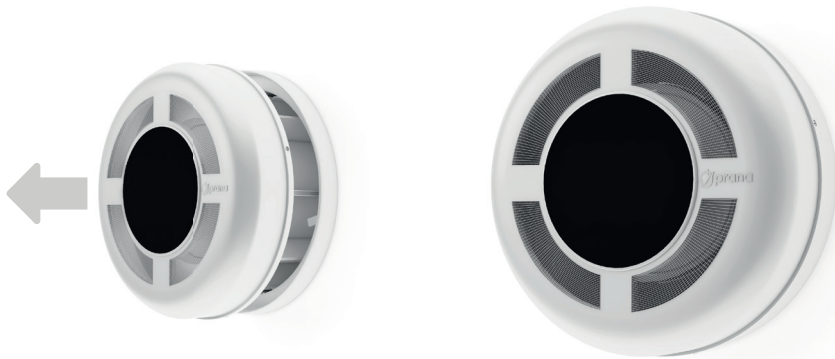

In order to make the first start and use the features correctly, read the quick user's guide.

POSSIBLE INSTALLATION ERRORS

Consequences that may indicate incorrect installation of the PRANA ventilation system.

- Non-compliance with the inclination of the installation:

Condensate flows down the wall in the room; short circuit; failure of climate sensors and control systems.

- Wrong condensate drain direction:

Condensate flows down the wall in the room; short circuit; freezing (icing) of the exhaust engine; failure of climate sensors and control systems

- Lack of the required distance from the air intake to the wall:

No air flow; failure of the engine of the supply channel; no ventilation effect; failure of climate sensors and control systems

- Radial displacement of the system in the housing:

Condensate flows down the wall in the room; short circuit; freezing (icing) of the exhaust engine; failure of climate sensors and control systems

- Insufficiently sealed housing:

Freezing of the system; freezing of the wall; infiltration in the gaps between the housing and the wall.

- Interference in the electrical part of the recuperator without the appropriate qualifications:

Short circuit; system failure.

A series of horizontal dashed lines for writing notes.

A series of horizontal dashed lines for writing notes.

A series of horizontal dashed lines for writing notes.



МОДЕЛЬНИЙ РЯД: PRANA 2022 ®